

## Bike-ABS

### Anti-lock braking system for bicycles with suspension fork

#### Technology

When braking sharply a cyclist may experience that the rear wheel loses contact with the pavement. Then there is a high risk of falling on or flying over the handlebar, especially in emergency braking. To prevent falls, the blockage of the front wheel should be prevented during braking.

The **Bike ABS** is a simple solution for bicycles with a suspension fork and a mechanical or hydraulic brake, which can also be retrofitted. Due to the compression during braking the **Bike ABS** reduces the pressure on the brake, so that the front wheel is not completely blocked. Thus, the loss of contact of the rear wheel through lifting is avoided and the risk of falling can be significantly reduced. Because the **Bike ABS** operates purely mechanically, it is ready for use at any time. The simple and robust construction stands for a high degree of safety and reliability.

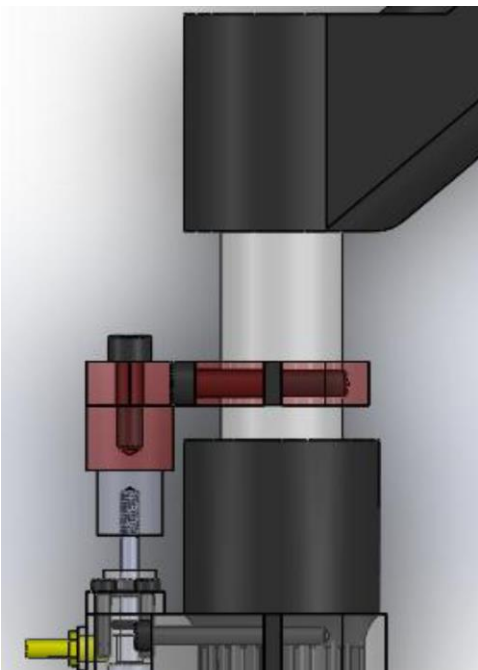

#### Commercial Opportunities

The **Bike ABS** can be used on all bicycles with a suspension fork on the front wheel. Especially for mountain bikes and pedelecs, which can reach high speeds, the **Bike ABS** considerably increases safety. The **Bike ABS** can also be easily retrofitted. It is robust and low maintenance.

#### Current Status

A German patent application was filed (DE 10 2015 012 016). On behalf of Bochum University of Applied Sciences,

we offer interested companies the opportunity to license or purchase as well as to further develop the technology.

An invention of the Bochum University of Applied Sciences.

#### Competitive Advantages

- Increased safety
- Simple and robust set up
- Low cost
- Retrofittable

#### Contact:

Ref. Nr. 4227

Andreas Brennemann, Dipl.-Ing.

#### PROvendis GmbH

Schlossstraße 11-15  
45468 Muelheim an der Ruhr  
Germany

Phone: +49 (0) 208 94 105 33

Fax: +49 (0) 208 94 105 50

E-Mail: [ab@provendis.info](mailto:ab@provendis.info)

Web: [www.provendis.info](http://www.provendis.info)